



Intec FB9500 Pro<sup>T</sup>  
Automatic Die Cutter

# Intec FB9500 Pro<sup>T</sup>



# Technical Specification

## Fully automated, cutting and creasing for the most demanding production environments

### Exceptional creasing and precision cutting

The FB9500 Pro<sup>T</sup> is a fully automated, tangential creasing digital die cutter delivering lightning speed performance, unparalleled media control and highly sophisticated, but user-friendly production functionality.

Produce high quality packaging, point of sale and labels using the ultrafast FB9500 Pro<sup>T</sup>. Incorporating the latest technology with patented back mark reading, the FB9500 Pro<sup>T</sup> delivers the speed and accuracy required by today's leading designers, printers and manufacturers.

### Market leading features

- **Digital process** allows cutting and creasing for any shape or design from one sheet to another automatically
- **QR code driven workflow** - simple to operate using the QR code file retrieval for mixed or batch job production
- **SmartMark registration** delivers incredible accuracy using ColorCut Pro software, supplied with the system
- **Fully optimised feed system** - advanced sheet separation processes, allow accurate and trouble free feeding, for fully unattended operation
- **Sheet pre-placement** - whilst cutting and creasing, the FB9500 Pro<sup>T</sup> will place the next sheet ready for production. This reduces the feed time and boosts productivity making the FB9500 Pro<sup>T</sup> one of the fastest systems available
- **Patented Rear Mark Scanning System** - optimise your creasing quality for certain jobs by creasing the back of the sheet without having to print marks or QR codes on both sides
- **2.5kg of creasing pressure** – more pressure produces deeper more defined creases for a high quality finish



FB9500 Pro <sup>T</sup> Technical Specifications		
<b>CUT AREA</b>	Auto Sheet Feed	Manual placement
Maximum media area	500mm x 720mm	550mm x 850mm
Effective contour cutting area	483mm x 700mm	495mm x 735mm (no mark scanning)
Media placement	Automatic sheet feeder or manual placement	
Media hold-down method	2 zone vacuum bed (high speed 750W vacuum pump included as standard)	
Cutting mat	Superior felt cutting underlay (one piece user replaceable) continuous belt	
Registration system	High speed CCD Camera	
Job recognition	Advanced QR code technology for instant file recognition and registration	
<b>CUTTING CONTROL</b>		
Mountable tools	Tangential Creasing Wheel with interchangeable wheels. Blade holder tool for a selection of blades	
Force / Pressure	Tool 1 (Crease) up to 2,500gf (2.5kg). Tool 2 (Cut) up to 1,300gf (1.3kg)	
Recommended media thickness/types	Paper/card up to 800micron. Max. depth: 1000micron (low density substrate i.e., rice paper / softboard)	
Speed - Three speed modes:	Fast mode 1,200mm/s; SD Standard mode 960mm/s; HD High quality mode 750mm/s	
Blades for label kiss cutting:	1 x Yellow - 1mm 30° cemented carbide blade - for thin film and very soft material 1 x Red - 1mm 45° cemented carbide blade - for adhesive stickers, thin card under 0.25mm 1 x Blue - 1mm 60° cemented carbide blade - for rigid media, (polyester sheets)	
Blades for card cutting:	3 x Red circlip - Industrial 1.4mm 45° circlip cemented carbide blade - default blade for cutting card stock and folding box board from 0.25 to 0.6mm thick 3 x Blue circlip - Industrial 1.4mm 60° circlip cemented carbide blade - use with high-intensity reflective film or magnetic media - suitable for cutting media from 0.5 to 1.2 mm thick (restricted to max limit of flatbed)	
Creasing tool	Tangential wheel crease tool with magnetic assist - variable pressure up to 2.5kg. 3 widths available for different media types.	
Pen holder:	Pen, plotting pen, also used for calibration sensor	
Output tray	Modular, moveable media collection tray	
<b>COMPATIBILITY MODE PC &amp; Mac</b>		
ColorCut Pro – Plugin (PC) <sup>§</sup>	Adobe® Illustrator® CS6, CC2024 - CC2024 or CorelDRAW® X8, 2017 - 2024 Graphics Suite	
ColorCut Pro – Plugin (Mac Client) <sup>§</sup>	Adobe Illustrator® CC 2022 - 2024. Mac operating systems: Big Sur to Sonoma	
ColorCut Pro 5 Standalone (PC) <sup>§</sup>	Job server - enables jobs created by the ColorCut Pro Plugin above to be cut at any time	
Specification <sup>†</sup>	Windows® 10/11 Pro x64 bit. 4GB of RAM (8GB recommended). Monitor res: 1280 x 960 minimum	
<b>AUTO SHEET FEEDER</b>		
Maximum media size	500mm x 720mm	
Minimum media size	196.85mm x 284.98mm	
Maximum media weight / stack height	25kg or 217.42mm. 2,000 sheets.	
Media pick up method	Quad (4) vacuum suction pads. Adjustable for portrait/landscape feeding	
Sheet separation features	Sheet jog with forward facing air blade separation with additional stainless steel sheet fingers and air pulse knock down jet	
Reverse side registration system	Patented additional 2 CCD camera systems to read sheet registration marks from rear side	
Productivity indicator	4 Light bar indicator	
<b>POWER REQUIREMENTS</b>		
Power requirements - Cutter	220 - 240V / 6.8A / 700W	
Power requirements - Vacuum pump	220 - 240V / 4.5A / 750W	
Power requirements - ASF	Auto Sheet Feeder (supplied by cutter)	
Power requirements - Compressor	220 - 240V / 3.6A / 780W (supplied with cutter)	

<sup>§</sup> Does not support illegal copies of Illustrator.† Full version only. Does not support 'Home and Student', 'Essentials' edition, or illegal copies of CorelDRAW.

# ColorCut Pro Server Station



The optional **ColorCut Pro Server Station** streamlines **production workflow** and automates **productivity**.

ColorCut Pro's client application is a plug in, that fully integrates with the leading drawing packages; Adobe® Illustrator® (Mac and PC) and CorelDRAW® (PC only).

**ColorCut Pro - Production Studio**, The core application for production and operating of the cutter. A stand alone application which stores cut files and enables users to cut previously prepared jobs, either by recalling the job number or by reading the QR code. Conveniently, ColorCut Pro's Job Library Server, can be used on PC's in remote production departments.

**Software and hardware.** Everything is designed to work together. Our Vision3 CCD Camera Registration System is integrated into the Intec FB9000 Pro-T to read registration marks and detect the position of sheets on the cutting table.





**Create.** ColorCut Pro is fully integrated, as a plugin, with Adobe® Illustrator® and CorelDRAW®, allowing users to edit, customize and export designs for use with ColorCut.

**ColorCut Pro's Job Library Manager:** Adds a sophisticated level of control enabling custom job naming and identification, searching, viewing and even assigning unique or custom actions to specific QR codes or job numbers (only available with the ColorCut Pro Server Station).

**Template Maker:** Create die-cut templates for a range of simple cartons and shaped items, with your own dimensions, in just a few seconds. This intuitive program allows for a wide range of options to tailor X, Y, Z dimensions, flaps, tucks, creasing and perforations etc. Templates can then be exported to Adobe Illustrator or CorelDRAW for immediate use. Template Maker is also only available with the server station.

**Skew compensation:** ColorCut Pro has an advanced feature to compensate for print skew or positioning skew. The Vision3 Registration Camera will read QR codes applied to printed files, and retrieve the cutting files from the ColorCut Pro Job Library database.

**Contour cutting:** Contour cutting involves placing a drawn outline around an object and using the Intec ColorCut flatbed to cut it.

-  The **Server Station** is supplied complete with a pre-installed Windows® PC and ColorCut Pro software suite, with a flat screen, monitor, mouse and keyboard.
-  **Production Studio** is the core operating software
-  **Template Maker** enables designers to create simple cartons and a variety of shaped items
-  **Job Library Manager** sophisticated job management, with custom action assignment.
-  **User Licence** allows 2 extra user seats

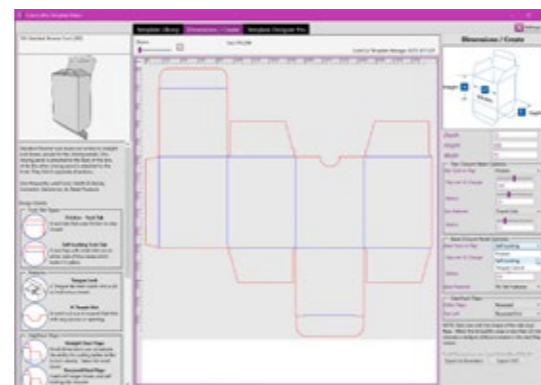
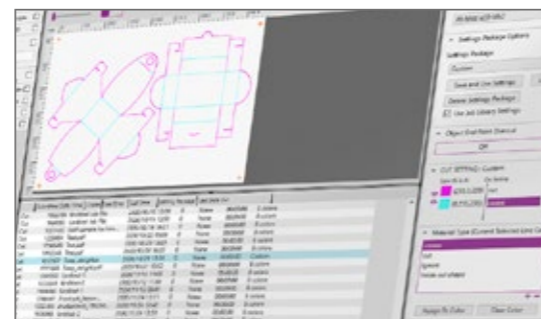

# ColorCut Pro Software

## How does ColorCut Pro work?

**Productivity controls for production runs.** With the auto-feeder, ColorCut Pro can cut a specific number of copies or continue to run until all sheets have been cut. In manual mode, multiple sheets can be placed on the table and ColorCut Pro can be set to search for each sheet and cut it - improving productivity. For complex designs it is possible to change the cutting sequence and order.

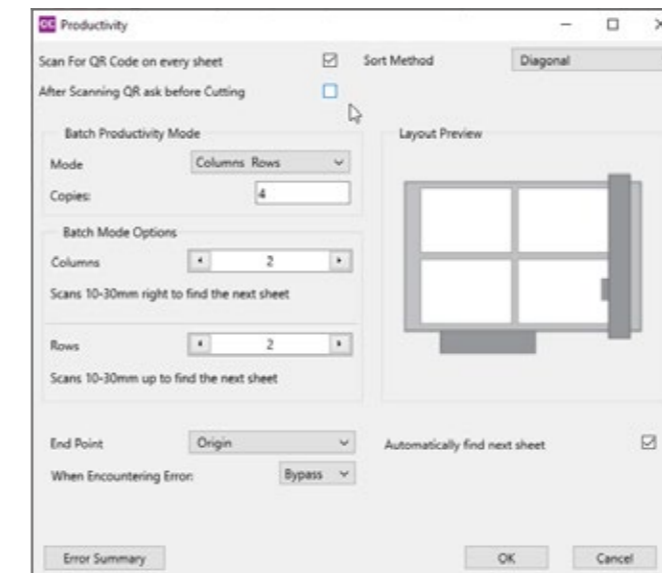

**Material database.** It's possible to assign a tool (either cutting or creasing), with tool speed and pressure for each action or material used. Settings can be saved so users can quickly and easily recall them in future. Using the 'SmartLine' Colour from the design that has been recognised by ColorCut Pro, assign the material process i.e. cutting 600 micron board, creasing, scoring or perforation.

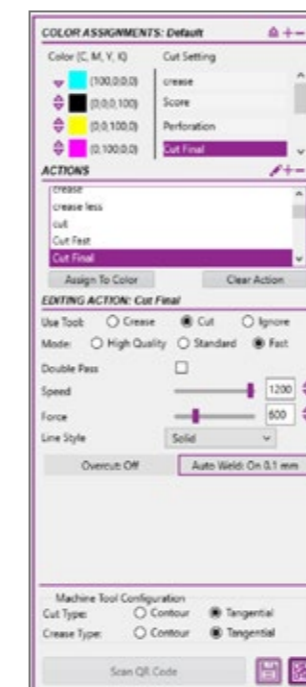

**Colour recognition.** Working with vector lines in the design, it is possible to set-up cutting/creasing processes using different line colours. This feature recognises different colours and allows users to set types of operation and the processing sequence, by Colour.

**Auto find jobs using QR codes.** When a designer uses the ColorCut Pro plugin to automatically add page registration marks, a QR code, job number and cut files are created and saved directly to the ColorCut Pro's Job Library. Once a job has been created with a QR code you benefit from faster, automated retrieval of the cut file at any required point.

In addition, the stand-alone version of ColorCut Pro can be installed on different computers, enabling other team members to cut the jobs - perhaps in another location - simply by using the QR code of the assigned job number.

**SmartLine control.** Solid lines can be over-ridden in designs, turning them into dashed lines, perforated cuts or even small tags to hold designs into the cut sheet.

**Click start.** Once positioned on the first registration mark, the Vision3 camera will automatically detect the 2nd, 3rd and 4th mark, the ColorCut Pro software automatically compensates for any scale, skew or position errors, allowing cutting to start automatically.

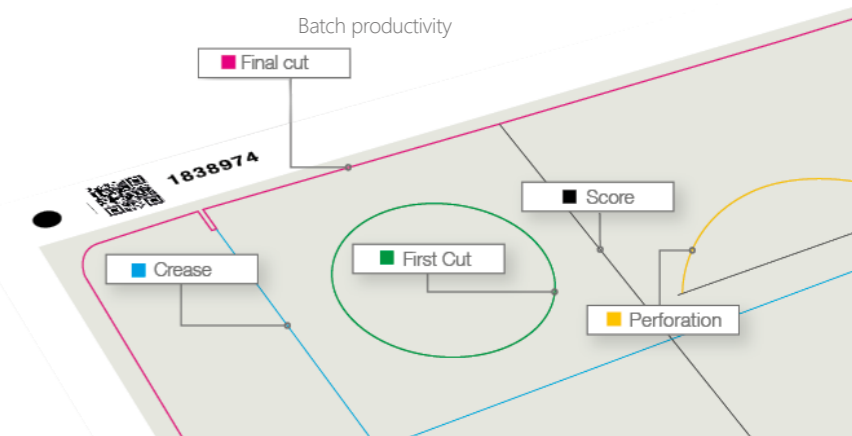

## A comprehensive range of tools and accessories, made for ColorCut.

A full range of original manufacturer parts and accessories are available for after-market purchase. Spares can be purchased at time of ordering the flatbed and/or shipped overnight as and when required.

**Creasing wheel tool.** Active Tangential Creasing Wheel tool with magnetic assist for easy change over. 3 different wheel options available for different media types. *Narrow tool provided with cutter.*



**Options**

- FBT0008A** - Tangential Creasing tool  
- Narrow 0.28mm
- FBT0008B** - Tangential Creasing tool  
- Medium 0.55mm
- FBT0008C** - Tangential Creasing tool  
- Wide 0.95mm

**Cutting tool.** Passive Blade Holder tool for contour - holds the cutting blade of choice. The tool is manually adjustable to obtain the desired amount of 'blade out' for the job in hand. *Provided with cutter.*



**Options**

- SC0003** - Passive Contour / Drag Blade Holder tool

**Cutting blades.** These ultra-sharp and hard-wearing swivel/drag blades come in two types and three blade angles. Either as a pack of three the same or as a mixed pack.

**Blades:**

- Yellow** 30° 1mm ø - for film, very soft material, thin label material
- Red** 45° 1mm ø - typically for labels, stickers, and thin paper/card
- Blue** 60° 1mm ø - for hard media. The sharply angled tip provides a sharper point edge. Suitable for penetrating harder media types

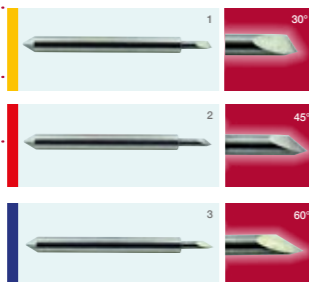

**Circlip blades:**

- Red** 45° 1.5mm ø - Most packing board up to 750 micron. Circlip provides better pressure and improves blade direction changes on dense media, from 0.25 to 0.75 mm thick
- Blue** 60° 1.5mm ø - For dense, rigid or thick media. Sharply angled tip provides a sharp point ideal for polyester, PVC or magnetic materials. 0.25 to 1.2mm



**Blade legend:**  
1. 30° blade  
2. 45° blade  
3. 60° blade  
4. 45° circlip knife  
5. 60° circlip knife

**Calibration tool.** A pen calibration tool is used at set up and then periodically, to calibrate the cutter.



**Cutting mat.** This replaceable grey felt mat is ideal for achieving crisp cuts and deep creasing lines on a wide range of substrates. The natural density of the fibres allows the vacuum flow to pass through it for sheet retention. The innovative 'jigsaw' style joint makes it easy to replace.



**Vacuum pump and silencer.** Powerful 750W vacuum pump with acoustic housing and safety valve.

**Acoustic silencer.** Reduces sound level of vacuum pump. Provided with vacuum fan.



### High-capacity and ultra-reliable feeding

The FB9500 Pro<sup>T</sup> is designed to provide high quality production with unattended operation. Unlike other cutters the Intec FB9500 Pro<sup>T</sup> incorporates five separate processes to ensure accurate feeding, separation and placement.

- Adjustable suction arm allows faultless sheet acquisition
- Automatic air blade prevents sheet curl
- Sheet feeder lowers to aid sheet collection
- Separation fingers ensure smooth sheet separation
- Jogging during sheet placement relieves static cling

### Dual tool power - digital accuracy

The dual tool head houses the active tangential creasing tool and passive cutting tool allowing you to cut and crease in one simple operation. Applying a creasing force of 2.5kg the tangential creasing wheel provides smoother more defined creases for high quality applications. The versatile passive blade can produce a range of actions including cut, tab, kiss cut, perforation and scoring. This combination of tools provides for a wider range of media handling.

The individual tool actions are controlled by the ColorCut Pro 5 Production Studio software supplied with the FB9500 Pro<sup>T</sup>. The tools can be set to apply the exact amounts of pressure and speed together with the type of cut required.

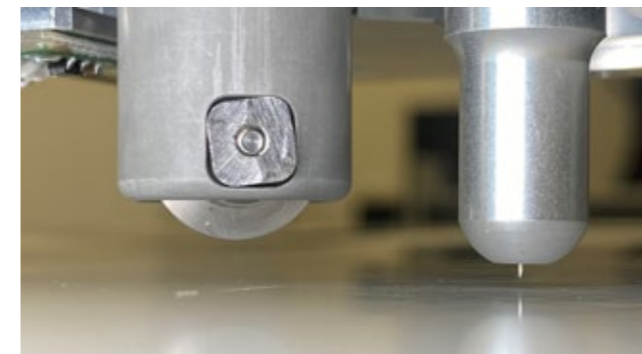

**Tangential** technology enables the FB9500 Pro<sup>T</sup> to lift the tool away from the media, rotate it and place it back on the media. This type of creasing tool provides a **smooth and more defined crease** and is particularly good for **thicker media**.

### New Ai control for ultimate optimisation

The FB9500 Pro<sup>T</sup> is built on our next generation Ai platform delivering a host of new features which redefines how automated cutting systems can be used.

You can customize a wide range of parameters including belt speed and acceleration, page separation (Jog), gravity restack and many more.

Easy and simple manual use or choose fully autonomous operation from the two 2 modes users can employ for cutting files.

**DIRECT mode** offers unparalleled flexibility and control direct from your PC. When creating jobs the ColorCut Pro 5 software plug in applies an auto assigned QR code to each design whilst auto saving the cut file to the ColorCut library.

**HELD mode** stores your job parameters wrapping all the required settings into a custom file that can be transferred to a storage device such as a memory stick. This can then be inserted into the cutter and the jobs can be accessed from the main cutter screen. This removes the need for a PC to be connected and is ideal for use in a manufacturing environment.

For both modes the cutter checks the QR code, retrieves the correct file and proceeds to cut and crease as required even if the sheet is accidentally loaded the wrong way round.



### Simple, Ergonomic touch screen control

The new 7" immersive touch screen gives complete finger tip control delivering visual feedback via the live camera. Feature rich operations provide advanced levels of control ensuring quality, accuracy and productivity.

The 7" touch screen control panel can pivot to suit the operators needs, the compact design with moveable collection tray allows the FB9500 Pro<sup>T</sup> to operate in the busiest of production environments.

# Technical Specification

## FB9500 Pro<sup>T</sup> Technical Specifications

<b>MEDIA COLLECTION TRAY</b>		
	<b>Packed</b>	<b>Unpacked</b>
Weight:	Included with the Cutter	18.5kg
Length:	Included with the Cutter	550mm
Width:	Included with the Cutter	475mm
<b>CUTTER</b>		
	<b>Packed</b>	<b>Unpacked</b>
Weight:	400kg	236kg
Length:	1,760mm	1,705mm
Width:	1,230mm	1,095mm
Height:	1,300mm	1,120mm
<b>AUTO SHEET FEEDER</b>		
	<b>Packed</b>	<b>Unpacked</b>
Weight:	295kg	142kg
Length:	1,555mm	895mm
Width:	1,040mm	1,000mm
Height:	1,400mm	1,225mm

\* Maximum dimensions relate to assembled machines and reflect full extremities of each device to allow for aspects such as tool beam and vacuum hose.

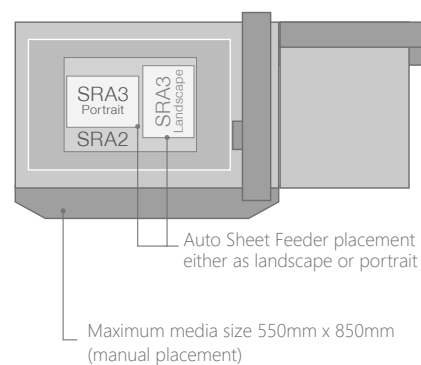
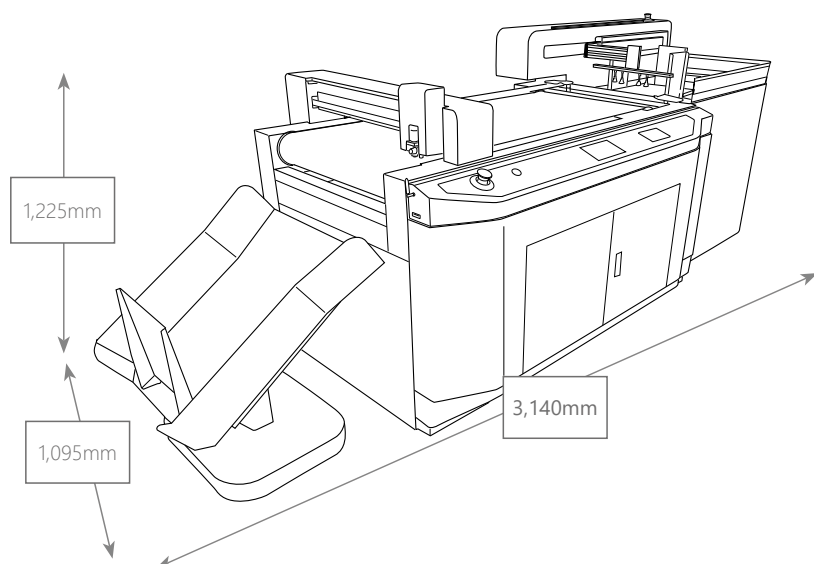

[www.intecprinters.com](http://www.intecprinters.com) • email: [sales@intecprinters.com](mailto:sales@intecprinters.com)

**\*Disclaimer** As part of our continued product improvement plan, specifications and information published here are subject to change without notice. All specifications are dependent on application, type of stock, temperature, RH and print engine used. Specifications quoted were measured on uncoated and unprinted stock. E & OE.